

JMS AG
 Jet Maintenance & Service
 Rainer-Haungs-Strasse 42
 77933 Lahr/Germany
 Phone +49 (7821) 9 94 69 – 0
 Fax +49 (7821) 9 94 69 – 100



Internet: <http://www.jms.aero/>
 eMail: <mailto:sales@jms.aero>
 HRB 705130 Amtsgericht Freiburg i.Br.
 VAT Reg No/USt.-IdNr.: DE270217003
 Doc. No. TDS J-AXLE-ARB-16.1_R00.docx

Datasheet:

p/n: J-AXLE-ARB-16.1

Recovery lifting beam: Use with 2 standard JMS axle jacks (not part of supply) for lifting of aircraft landing gears at jacking points with very low (on-rim) gear conditions.

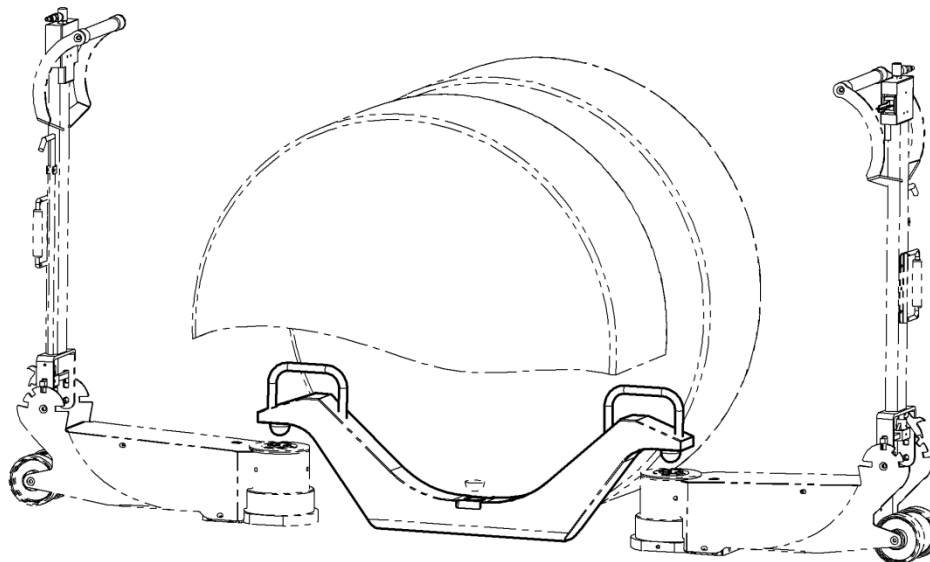

Standard features:

- Light weight design
- Operating handles on each end
- Interchangeable Jacking adapters SR3/4" convex / concave

Documentation:

- Proof load/quality inspection certificate
- Technical manual incl. illustrated spare parts list
- COC Certificate of Conformity
- CE Declaration of Conformity

Compliance with the following relevant directives, standards and OEM documents:

- EC machinery directive 2006/42/EC
- EN 1494: 2009
- EN 1915-1: 2009
- EN 1915-2: 2009
- EN 12312-19: 2009
- Maintenance facility (equipment) planning documents from aircraft manufacturer

Net weight (without options):

- ca. 16 kg / 35 lbs

Shipping informations incl packing:

Approx. Weight	Approx. shipping Dim. l x w x h	Approx. Volume
[kg]	[mm]	[m³]
41	1200 x 600 x 220	0,15
[lbs]	[inch]	[ft³]
90	47 x 23 x 9	5.6