



Datasheet J-AXLE A-series: p/n: J-AXLE60A

Axle jack for lifting of A/C at landing gear jacking points for removal & installation of wheels and brakes.

Standard features: (version without handpump)

- Fast stroke system with automatic piston retraction
- Air/nitrogen operated hydraulic pump, connection G¼" female thread
 Possible media: Compressed air, nitrogen from bottles or inflated tires (via option PHA)
 Air consumption: UP 380 l/min (100 gal/min), DOWN 80 l/min (21 gal/min)
- Universal jacking adapter, cup size SR ¾"
- Operating handle with several locking positions
- Hydraulic cylinder with 2 stages, extension screw and silicone cylinder protection
- Skydrol resistant paint, standard color yellow RAL 1018
- Easy to maintain through modular design of components
- Working pressure: from 8 to 15 bar (116 to 217 psi)
- Working temperature: from -20°C to +50°C (-4°F to 122°F)
- Hydraulic fluid: Automatic transmission fluid (e.g. ATF Dexron II D)

Options (at extra charges): please refer to separate datasheets for more information

- Option HPA Hydraulic hand pump for J-Axle (weight 8kg/17.6lbs)
- J-AXLE-PHA tire hose with SCHRADER connector (LARGE and SMALL bore)
- J-AXLE-TB45-60-90 fly-away transport box for axle jack
- J-Cart-A /-2A cart for transport of 1 / 2 axle jacks
- 227A-JMS wheel change dolly
- J-WF1 wheel fork
- J-TF60 /-150 universal load test fixtures; applicable for any model/brand

Documentation:

- Proof load/quality inspection certificate
- Technical manual incl. illustrated spare parts list
- COC Certificate of Conformity
- CE Declaration of Conformity

Compliance with the following relevant directives, standards and OEM documents:

- EC machinery directive 2006/42/EC
- EN 1494: 2009
- EN 1915-1: 2009
- EN 1915-2: 2009
- EN 12312-19: 2009
- Maintenance facility (equipment) planning documents from aircraft manufacturer (see page 2, aircraft application)

Net weight (without options):

- 104 kg / 229 lbs

Shipping information incl. packing: (refers to single units; varies for packages)

approx. weight	approx. shipping dim. l x w x h	approx. volume
[kg] 119	[mm] 1370 x 650 x 650	[m³] 0,58
[lbs] 262	[inch] 54 x 25.6 x 25.6	[ft³] 20

Datasheet J-AXLE A-series:

p/n: J-AXLE60A

Aircraft applications:

A/C Type	NLG	MLG WLG	CLG
A220-100/-300 (CS100/300)	1	1, 2, 3	n.a.
A300-B2/-B4/-600	1	1	n.a.
A310-200/-300	1	1	n.a.
A318/A319/A320/A321 + neo	1	1	n.a.
A330-200/-300	1	1	n.a.
A340-200/-300	1	1	1
A340-500/-600	1,2,3	-	-
B707, KC-135, E-3/-6/-8	1	1	n.a.
B727-100/-200	1	1	n.a.
B737-100/-200	-	1	n.a.
B737-300/-400/-500	-	1	n.a.
B737-600/-700/-800/-900, BBJ	-	1	n.a.
B737 MAX 7/8/82/9	-	1	n.a.

A/C Type	NLG	MLG WLG	CLG
B747-100/-200/-300/-SP	1	1	n.a.
B747-400/-400ER/-F	-	1	n.a.
B757-200/-300	1	1	n.a.
B767-200/-300/-400ER	1	1	n.a.
B777-200/-200ER/-300	1	-	n.a.
B777-200LR/-300ER	1	-	n.a.
B787-8/-9/-10	1	1, 2	n.a.
AN-148/-158	-	1, 2	n.a.
DC-10/MD-11/-F	1	1	n.a.
Fokker 50	-	1	n.a.
L1011-100/-200/-500	1	1	n.a.
Sukhoi Superjet 100	-	1	n.a.
Embraer 190/195	-	1	n.a.

Wheel conditions: 1 = normal, 2 = 1 flat tire, 3 = 2 flat tires, 4 = on rim

Drawing:

Note: picture shows optional handpump

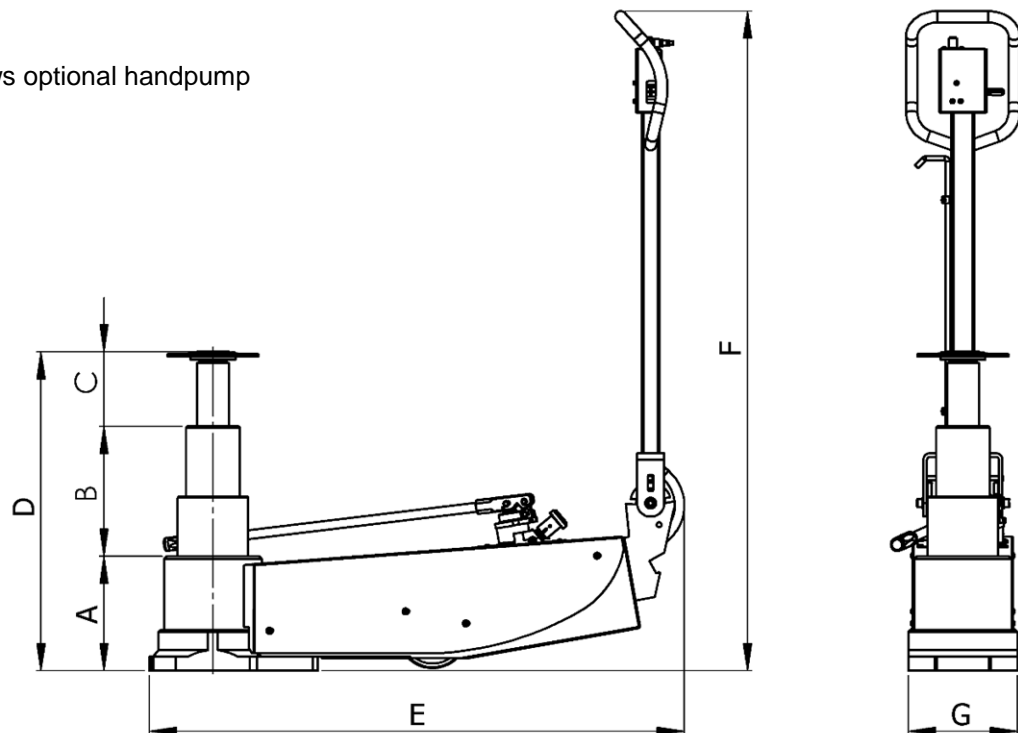

Technical specifications:

Capacity	A Min. height	B Hydr. Lift	C Screw Ext.	D Max. height	E Body length	F Handle height	G Base width	R Jacking adapter	Max. Ground pressure
[t]	[mm]	[mm]	[mm]	[mm]	[mm]	[mm]	[mm]	[mm]	[N/mm ²]
60	242	278	130	650	1118	1130	220	R19,05	8,8
[tn sh.]	[inch]	[inch]	[inch]	[inch]	[inch]	[inch]	[inch]	[inch]	[psi]
66	9.5	10.9	5.1	25.6	44.0	44.5	8.7	R3/4	127.6