

JMS AG
 Jet Maintenance & Service
 Rainer-Haungs-Strasse 42
 77933 Lahr/Germany
 Phone +49 (7821) 9 94 69 – 0
 Fax +49 (7821) 9 94 69 – 100



Internet: <http://www.jms.aero/>
 eMail: <mailto:sales@jms.aero>

HRB 705130 Amtsgericht Freiburg i.Br.
 VAT Reg No/USt.-IdNr.: DE270217003

Doc. No. TDS J-CART-2BO-BOOSTER-R02.docx

Datasheet:

p/n: J-CART-2BO-BOOSTER

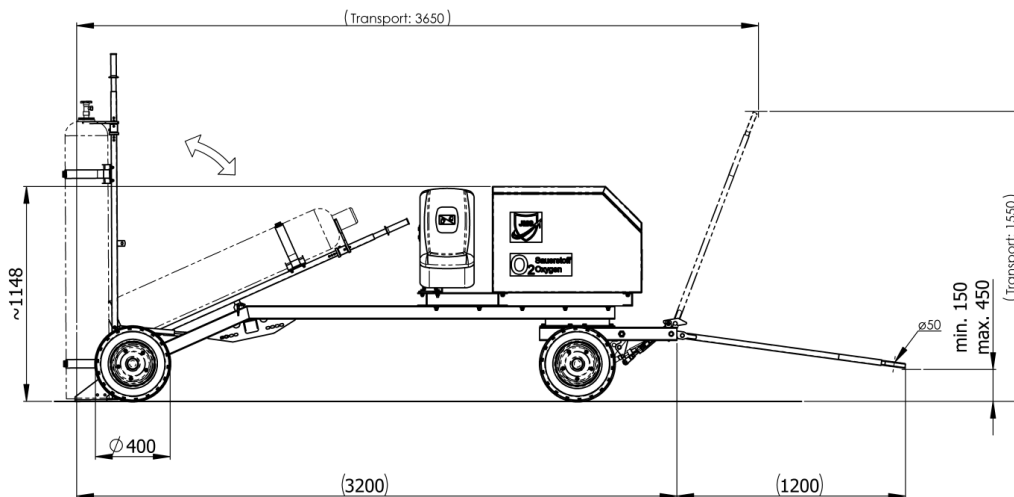

Description:

Aircraft/Cockpit Oxygen/O₂ servicing cart for servicing 1850 psi standard Aviator's Breathing Oxygen bottles

Standard features/including:

- Trailer/steel frame
- Tow bar with parking brake / tow-eye with diam. 3"/76.2mm,
- Four air-inflated tires
- 2 storage racks for standard O₂ bottles, V=40 l / 50l (with p_{max} = 250bar /3625 psi) each bottle individually replaceable in separate tilt frame
- Frame hot-dip galvanized
- Grounding cable
- MAXIMATOR pneumatic oxygen booster with operator panel (incl. inlet/outlet manometers + connection hoses etc.)
- Aircraft O₂ panel servicing hose, 10 m (connectors to be specified individually)
- 6kg ABC Powder Fire-Extinguisher

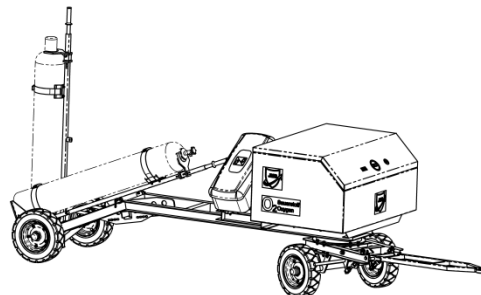

Options (at extra charges):

- Puncture-proof tires
 → Option R4
- Coupling Oxygen
 3/8-24 UNF, Brass
 Mates with a/c adapter AND10089-3
 → J-CART-OC3/8-24
- Coupling Oxygen
 9/16-18 UNF, Messing
 Filling connector 9/16-18 UNF (SCOTT)
 → J-CART-OC9/16-18
- Oxygen bottle, p=200 bar, V=50 l incl. valve
 → J-CART-BOTTLE-O2
- Bottle adapter for country specific gas bottles
 → J-Adapter-Oxx

Net weight (without options):

- 360 kg / 793 lbs

Documentation:

- Technical manual
 incl. illustrated spare parts list
- COC Certificate of Conformity

Shipping dimensions incl. packing:

Approx. Weight	Approx. shipping Dim. l x w x h	Approx. Volume
[kg]	[mm]	[m ³]
370	3650 x 1150 x 1550	6,5
[lbs]	[inch]	[ft ³]
815	142 x 45 x 61	230

We reserve the right to update this datasheet at any time w/o prior notice!