

**JMS AG**

Rainer-Haungs-Straße 42  
77933 Lahr/Germany

URL: <http://www.jms.aero/>  
E-Mail: [sales@jms.aero](mailto:sales@jms.aero)

**J-CART-UNIV1**

Doc. No. TDS J-CART-UNIV1\_R04.docx

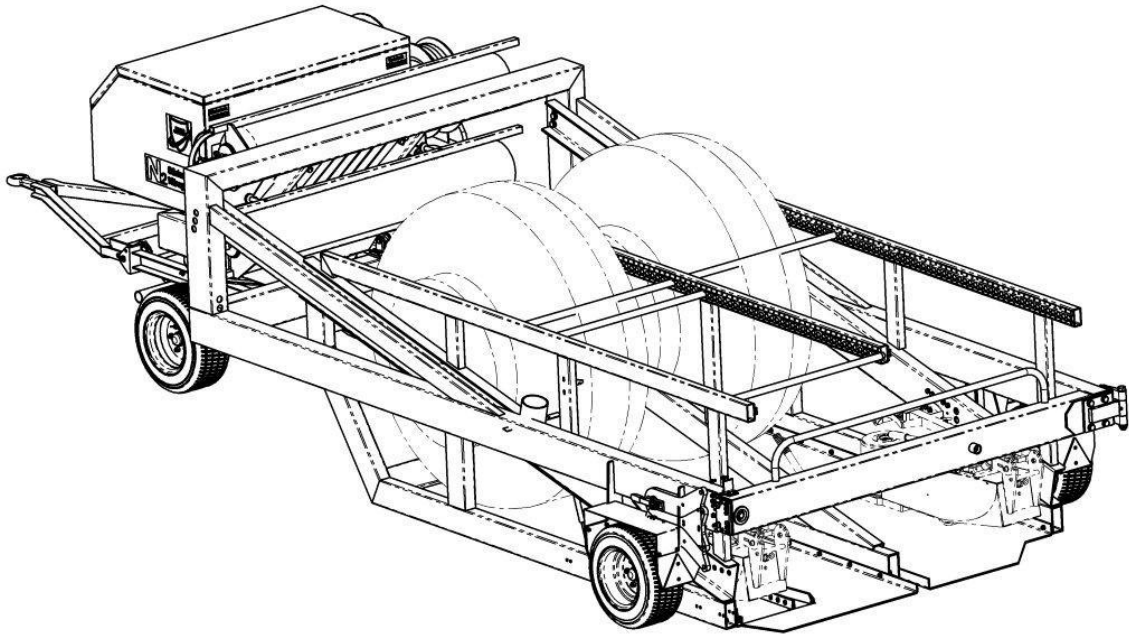
**Datasheet:****Description:**

Universal ramp service cart for aircraft tire service & nitrogen maintenance. Provides transport for spare tires and all required tools to and from the aircraft on the ramp. Transport capabilities for:

- up to 2 off wide-body MLG tires, max. size 1400x530 R23 (Airbus A380-800 BLG/WLG) or NLG tires in any combination
- up to 2 off J-AXLE-Series aircraft axle jacks, e.g. J-AXLE90AHPA or smaller, (not part of J-CART-UNIV1 supply)
- 1 off p/n 227A-JMS wheel-brake-changer (not part of J-CART-UNIV1 supply)

Tires plus axle jacks and wheel-brake-changer can be conveniently rolled-on/rolled-of ("Ro-Ro") evenly on tarmac level (no ramp required), providing maximum convenience and operator safety!

**Standard features/including:**

- Trailer-style trolley with steel frame, 145 mm ground clearance of cargo box
- Design towing speed: 40 km/h
- Four air-inflated tires, diam. 400 mm
- Tow eye, hook diam. 50 mm
- Frame and all components hot-dip galvanized
- Integrated hydraulic system with one cylinder, pump and valve to safely operate lifting/lowering of the transport platform; mechanical interlock in up-position

**JMS AG**

Rainer-Haungs-Straße 42  
77933 Lahr/Germany

URL: <http://www.jms.aero/>  
E-Mail: [sales@jms.aero](mailto:sales@jms.aero)

**J-CART-UNIV1**

Doc. No. TDS J-CART-UNIV1\_R04.docx

- 2 storage racks for standard nitrogen bottles, V=50 l, p=200 bar/2900 psi; each bottle is individually replaceable in a separate fixture;  
(nitrogen bottles/cylinders not part of J-CART-UNIV1 supply)
- LP (low-pressure) nitrogen circuit including pressure regulator for 0-40 bar/580 psi outlet pressure (incl. inlet/outlet pressure gauges + hoses), completely installed including all piping etc. allowing tire filling operations as well as nitrogen supply for axle jack operation on tarmac
- Nitrogen servicing hose, 12 m, on spring-retracted hose-drum

**Options/customizing features available:**

- Pneumatic-hydraulic drive for lifting/lowering of cargo box; allows convenient lifting/lowering of the Ro-Ro platform by making use of pneumatic pressure available from nitrogen bottles.
- Weather-proof enclosure of cargo box  
(bottom part: metal plating; top part: canvas-type cover in heavy-duty truck/semi-trailer quality)
- Booster unit (piston-type) with additional HP (high-pressure) circuit 2-300 bar (29-4350 psi) enabling nitrogen service on aircraft shock-strut/oleo, brake accumulator etc., completely installed including 12m HP-hose on spring-retracted hose-drum
- Tire inflator gun, SCHRADER valve-adapter for shock-strut, brake accumulator inflating etc.

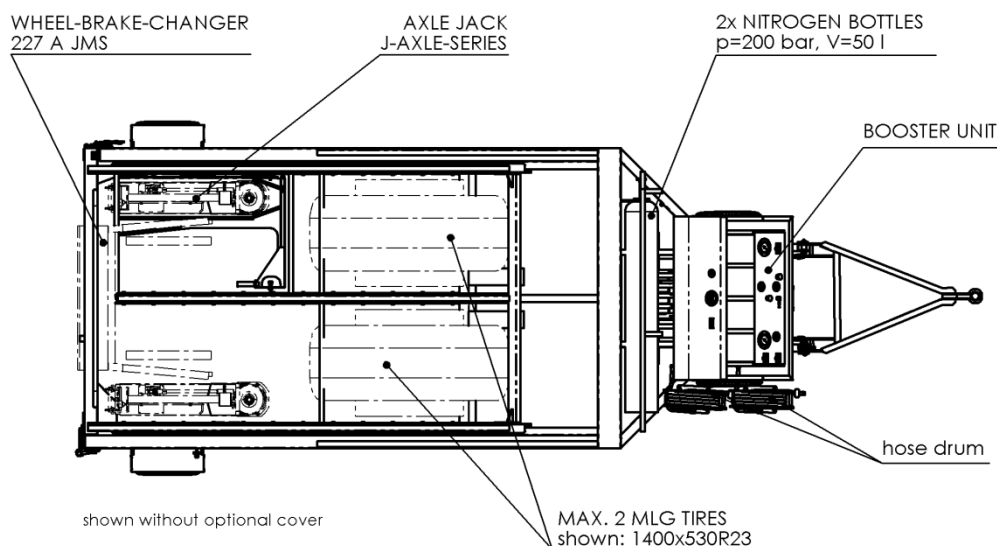
**Layout:****Documentation:**

- Operation and maintenance manual including illustrated spare parts list
- COC, Certificate of Conformity
- CE Declaration of Conformity
- Calibration certificate of aircraft tire inflator gun

**JMS AG**  
Rainer-Haungs-Straße 42  
77933 Lahr/Germany

URL: <http://www.jms.aero/>  
E-Mail: [sales@jms.aero](mailto:sales@jms.aero)



# J-CART-UNIV1

Doc. No. TDS J-CART-UNIV1\_R04.docx

## Dimensions:

**Max. payload = 1.500 kg/3.300 lbs**

