

JMS AG

Rainer-Haungs-Straße 42
77933 Lahr/Germany

URL: <http://www.jms.aero/>
E-Mail: sales@jms.aero

**J-POD05T01**

Doc. No.: TDS J-POD05T01_R03.docx

Datasheet J-POD-series**Standard features:**

- Tripod steel frame
- Hydraulic lift cylinder (2-stage telescopic) with hard-chrome plated piston
- Manual safety lock-nuts (preventing cylinders from descending in case of hydraulic pressure drop/failure)
- Interchangeable spherical jacking adapter, (size R3/4" convex)
- Manually height adjustable foot pads
- Castors
- Hydraulic steel tank incl. oil level (sight glass)
- Dual stage hand pump (LP/HP)
- 2K-PU SKYDROL-resistant paint
- Standard color RAL 1018 (zinc yellow)

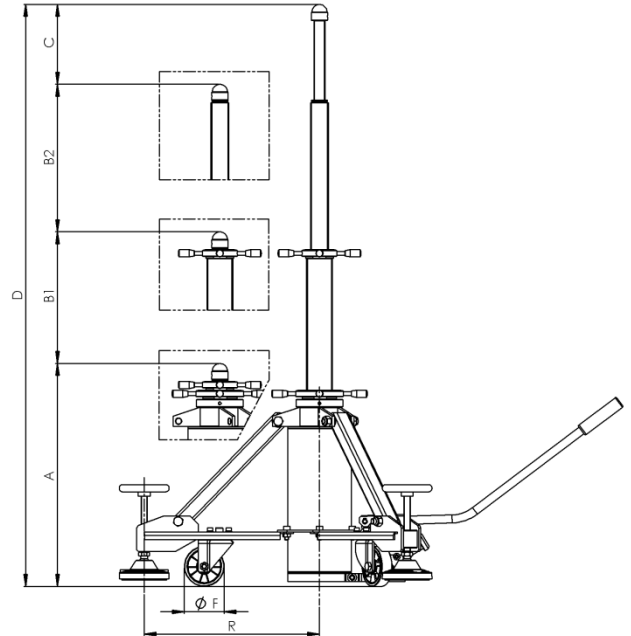
**Options available:**

- Customized color in accordance with RAL color coding scheme

Documentation:

- Operation & maintenance manual incl. illustrated spare parts list
- Proof load test certificate
- COC (Certificate of Conformity)
- CE Declaration of Conformity

Aircraft application:

Mil-Mi-8/ -17 Helicopter
Dash 8 Q-Series

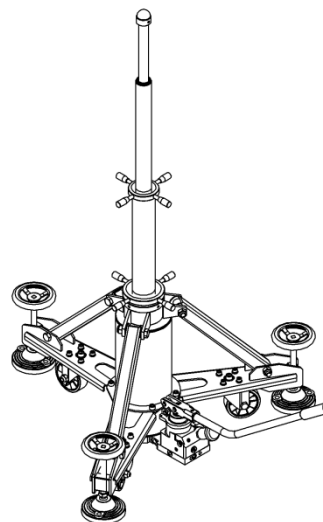
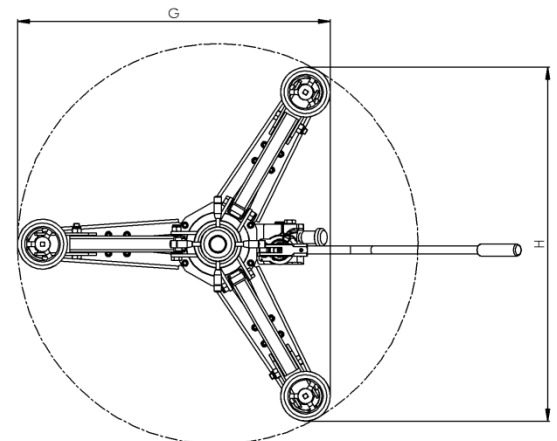

Capacity	A Min. height	B Hydraulic Lift	C Screw Extension	D Max. height	E Diameter Foot plates	F Diameter castors	G	H	R Radius Tripod leg
[t]	[mm]	[mm]	[mm]	[mm]	[mm]	[mm]	[mm]	[mm]	[mm]
5	559	700	200	1459	125	100	785	887	440
[tn sh.]	[inch]	[inch]	[inch]	[inch]	[inch]	[inch]	[inch]	[inch]	[inch]
5.5	22.0	27.6	7.9	57.4	4.9	3.9	30.9	34.9	17.3

Packing information on request.

We reserve the right to update this datasheet at any time w/o prior notice!