

JMS AG

Rainer-Haungs-Straße 42
77933 Lahr/Germany

URL: <http://www.jms.aero/>
E-Mail: sales@jms.aero

**J-POD10SX02**

Doc. No.: TDS_J-POD10SX02_R04.docx

Datasheet J-POD-series**Standard features:**

- Tripod steel frame
- Hydraulic lift cylinder (single stage) with hard-chrome plated piston and **integrated automatic mechanical INTERLOCK-system** (preventing cylinder from descending in case of hydraulic pressure drop/failure)
- Interchangeable spherical jacking adapter, R3/4" concave
- Manually height adjustable foot pads
- Spring loaded heavy-duty castors with directional lock
- Hydraulic steel tank incl. oil level (sight glass) and filter
- Dual stage hand pump (LP/HP)
- Electrically driven hydraulic pump
- 2K-PU SKYDROL-resistant paint
- Standard color RAL 1007 (daffodil yellow)
- Tow-bar with $\varnothing 76\text{mm}$ / 3" tow-eye

Options available:

- Air-driven hydr. pump (instead of electr. driven hydr. pump)
→ Option J-POD-AD
- Hydr. height adjustable castors for tripod jacks
→ Option J-POD-HC
- Mechanical indicator for lifting height
→ Option J-POD-MI
- Tow-bar with other tow-eye dimensions
→ Option J-POD-TBx
- Customized color in accordance with RAL color coding scheme
→ Option J-POD-RAL
- Automatic lifting and leveling system
→ J-SLS

Documentation:

- Operation & maintenance manual incl. illustrated spare parts list
- Proof load test certificate
- COC (Certificate of Conformity)
- CE Declaration of Conformity

Aircraft application:

BOEING 737-100 through -900, BBJ, MAX -7/-8/-9
TAIL

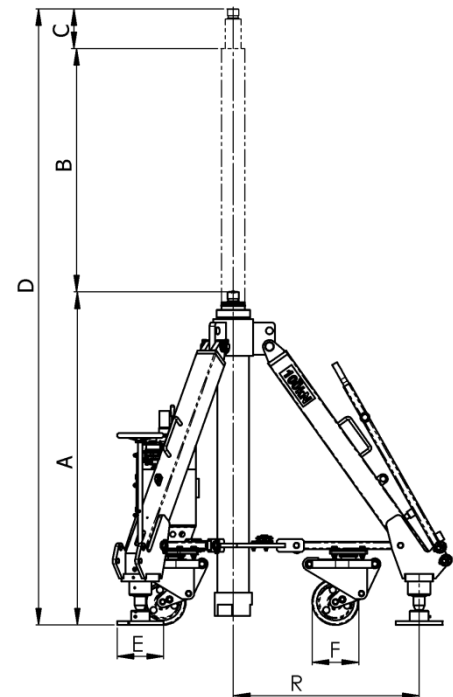

Picture may show options.

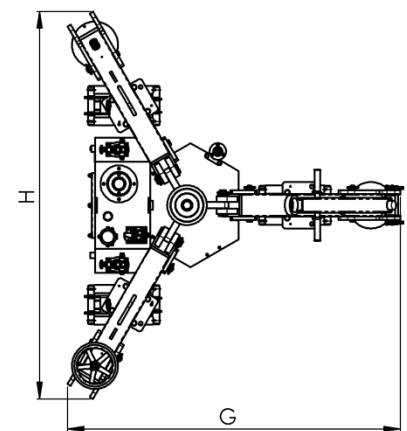

Capacity	A Min. height	B Hydr. Lift	C Screw Ext.	D Max. height	E	F	G	H	R
[t]	[mm]	[mm]	[mm]	[mm]	[mm]	[mm]	[mm]	[mm]	[mm]
10	2530	1100	150	3630	250	250	2050	2302	1150
[tn sh.]	[inch]	[inch]	[inch]	[inch]	[inch]	[inch]	[inch]	[inch]	[inch]
11.0	99.6	43.3	5.9	142.9	9.8	9.8	80.7	90.6	45.3

Packing information on request.

We reserve the right to update this datasheet at any time w/o prior notice!