

**JMS AG**

Rainer-Haungs-Straße 42  
77933 Lahr/Germany

URL: <http://www.jms.aero/>  
E-Mail: [sales@jms.aero](mailto:sales@jms.aero)

**J-POD10SX06**

Doc. No.: TDS J-POD10SX06\_R00.docx

**Datasheet J-POD-series****Standard features:**

- Tripod steel frame
- Hydraulic lift cylinder (single stage) with hard-chrome plated piston and **integrated automatic mechanical INTERLOCK-system** (preventing cylinder from descending in case of hydraulic pressure drop/failure)
- Interchangeable spherical jacking adapter, R3/4" concave
- Manually height adjustable foot pads
- Spring-loaded heavy-duty steel swivel castors
- Directional locking mechanism
- Hydraulic steel tank incl. oil level (sight glass) and filter
- Dual stage hand pump (LP/HP)
- Electrical-hydraulic pump incl. switch cabinet, ready for manual and J-SLS operation (synchronized lifting/lowering)
- Power requirements: 3-phase AC 380V, 50Hz
- 2K-PU SKYDROL-resistant paint
- Standard color RAL 1007 (daffodil yellow)

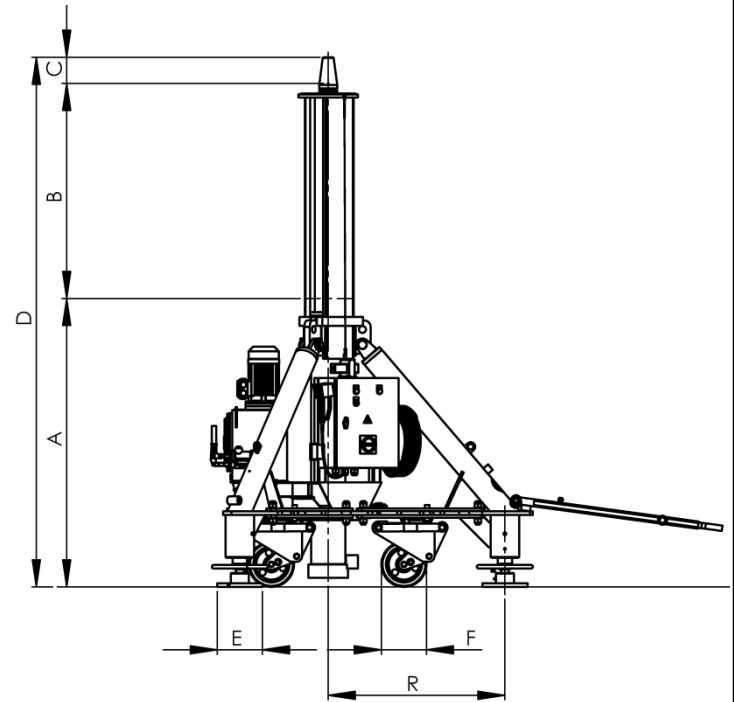
**Documentation:**

- Operation & maintenance manual incl. illustrated spare parts list and wiring diagrams
- Proof load test certificate
- COC (Certificate of Conformity)
- CE Declaration of Conformity

**Aircraft application:**

IRKUT MS-21-200/ -300  
**FWD BODY/ NOSE (MX)**

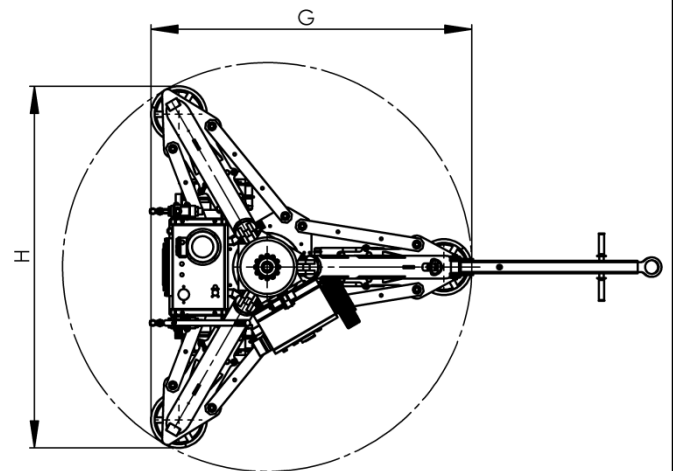

Picture shown above is exemplary only and may contain options.

Capacity	A Min. height	B Hydr. Lift	C Adapter Ext.	D Max. height	E	F	G	H	R
[t] <b>10</b>	[mm] <b>1450</b>	[mm] <b>1140</b>	[mm] -	[mm] <b>2590</b>	[mm] <b>250</b>	[mm] <b>250</b>	[mm] <b>1540</b>	[mm] <b>1740</b>	[mm] <b>860</b>
[tn sh.] <b>11.0</b>	[inch] <b>57.1</b>	[inch] <b>44.9</b>	[inch] -	[inch] <b>102.0</b>	[inch] <b>9.8</b>	[inch] <b>9.8</b>	[inch] <b>60.6</b>	[inch] <b>68.5</b>	[inch] <b>33.9</b>

Packing information on request.

We reserve the right to update this datasheet at any time w/o prior notice!