

**JMS AG**

Rainer-Haungs-Straße 42  
77933 Lahr/Germany

URL: <http://www.jms.aero/>  
E-Mail: [sales@jms.aero](mailto:sales@jms.aero)

**J-POD35SX04**

Doc. No.: TDS J-POD35SX04\_R04.docx

**Datasheet J-POD-series****Standard features:**

- Tripod steel frame
- Hydraulic lift cylinder (single stage) with hard-chrome plated piston and **integrated automatic mechanical INTERLOCK-system** (preventing cylinder from descending in case of hydraulic pressure drop/failure)
- Interchangeable spherical jacking adapter, R3/4" concave
- Manually height adjustable foot pads
- Spring-loaded heavy-duty steel swivel castors
- Directional locking mechanism
- Hydraulic steel tank incl. oil level (sight glass) and filter
- Dual stage hand pump (LP/HP)
- Electrical-hydraulic pump incl. switch cabinet, ready for manual and J-SLS operation (synchronized lifting/lowering)
- Power requirements: 3-phase AC 380V, 50Hz
- 2K-PU SKYDROL-resistant paint
- Standard color RAL 1007 (daffodil yellow)

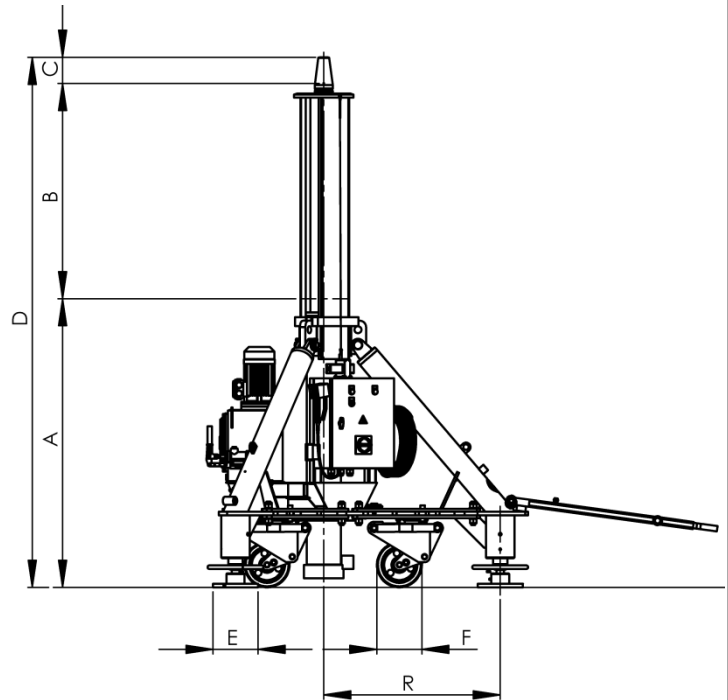
**Documentation:**

- Operation & maintenance manual incl. illustrated spare parts list and wiring diagrams
- Proof load test certificate
- COC (Certificate of Conformity)
- CE Declaration of Conformity

**Aircraft application:**

IRKUT MS-21  
**WING (FAL)**

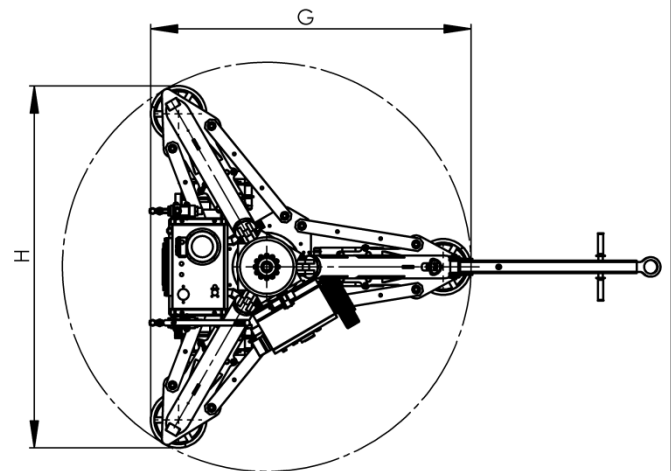
**Net weight:**

1500 kg / 3307 lbs

Picture shown above is exemplary only and may contain options.

Capacity	A Min. height	B Hydr. Lift	C Adapter Ext.	D Max. height	E	F	G	H	R
[t] <b>35</b>	[mm] <b>2725</b>	[mm] <b>1195</b>	[mm] -	[mm] <b>3920</b>	[mm] <b>250</b>	[mm] <b>250</b>	[mm] <b>2260</b>	[mm] <b>2563</b>	[mm] <b>1320</b>
[tn sh.] <b>38.6</b>	[inch] <b>107.3</b>	[inch] <b>47.0</b>	[inch] -	[inch] <b>154.3</b>	[inch] <b>9.8</b>	[inch] <b>9.8</b>	[inch] <b>89.0</b>	[inch] <b>100.9</b>	[inch] <b>52.0</b>

Packing information on request.

We reserve the right to update this datasheet at any time w/o prior notice!