

JMS AG

Rainer-Haungs-Straße 42
77933 Lahr/Germany

URL: <http://www.jms.aero/>
E-Mail: sales@jms.aero

**J-POD35SX05**

Doc. No.: TDS J-POD35SX05_R00.docx

Datasheet J-POD-series**Standard features:**

- Tripod steel frame
- Hydraulic lift cylinder (single stage) with hard-chrome plated piston and **integrated automatic mechanical INTERLOCK-system** (preventing cylinder from descending in case of hydraulic pressure drop/failure)
- Interchangeable spherical jacking adapter, R3/4" concave
- Manually height adjustable foot pads
- Spring-loaded heavy-duty steel swivel castors
- Directional locking mechanism
- Hydraulic steel tank incl. oil level (sight glass) and filter
- Dual stage hand pump (LP/HP)
- Electrical-hydraulic pump incl. switch cabinet, ready for manual and J-SLS operation (synchronized lifting/lowering)
- Power requirements: 3-phase AC 380V, 50Hz
- 2K-PU SKYDROL-resistant paint
- Standard color RAL 1007 (daffodil yellow)

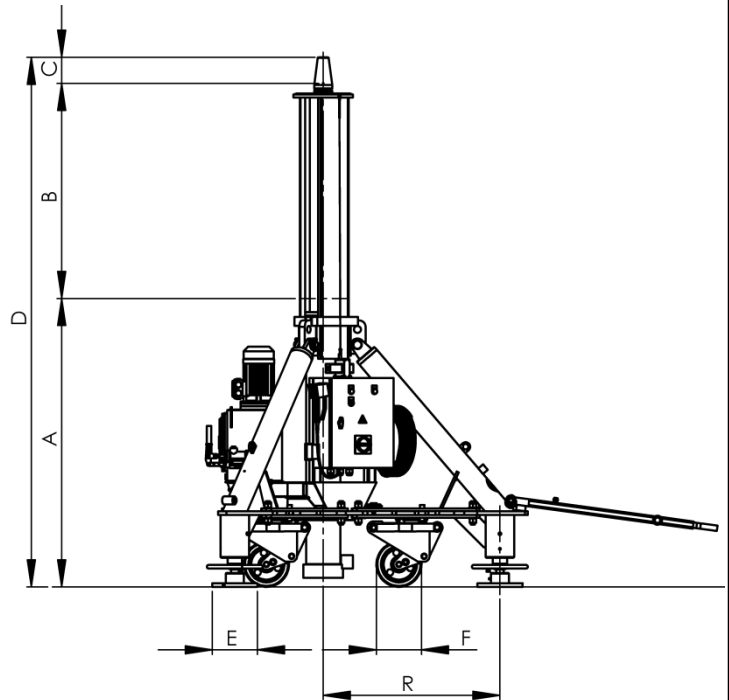
**Documentation:**

- Operation & maintenance manual incl. illustrated spare parts list and wiring diagrams
- Proof load test certificate
- COC (Certificate of Conformity)
- CE Declaration of Conformity

Aircraft application:

IRKUT MS-21-200/ -300
WING (MX)

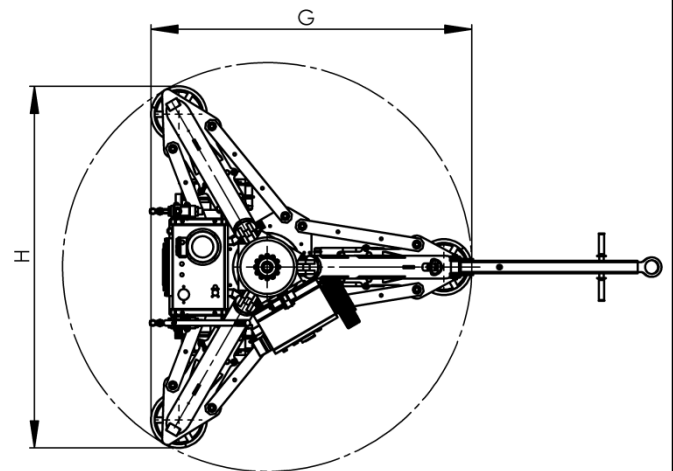

Picture shown above is exemplary only and may contain options.

Capacity	A Min. height	B Hydr. Lift	C Adapter Ext.	D Max. height	E	F	G	H	R
[t]	[mm]	[mm]	[mm]	[mm]	[mm]	[mm]	[mm]	[mm]	[mm]
35	2600	1205	-	3805	250	250	2140	2432	1260
[tn sh.]	[inch]	[inch]	[inch]	[inch]	[inch]	[inch]	[inch]	[inch]	[inch]
38.6	102.4	47.4	-	149.8	9.8	9.8	84.3	95.7	49.6

Packing information on request.

We reserve the right to update this datasheet at any time w/o prior notice!