

JMS AG

Rainer-Haungs-Straße 42
77933 Lahr/Germany

URL: <http://www.jms.aero/>
E-Mail: sales@jms.aero

**J-STAY02MX01**

Doc. No.: TDS_J-STAY02MX01_R02.docx

Datasheet J-STAY-series**Standard features:**

- Tripod steel frame
- Jackscrew, manually operated
- Interchangeable spherical jacking adapter, R3/4" concave
- Manually height adjustable foot pads
- Heavy-duty castors with locks
- Tow-bar with \varnothing 76,2mm / 3" tow-eye
- 2K-PU SKYDROL-resistant paint
- Standard color RAL 1007 (daffodil yellow)

Options available:

- Customized color in accordance with RAL color coding scheme

Documentation:

- Operation & maintenance manual incl. illustrated spare parts list
- Proof load test certificate
- COC (Certificate of Conformity)
- CE Declaration of Conformity

Aircraft application:

AIRBUS A318/A319/A320/A321 (**TAIL STAY**)

BOEING 757-200/-300 (**TAIL STAY**)

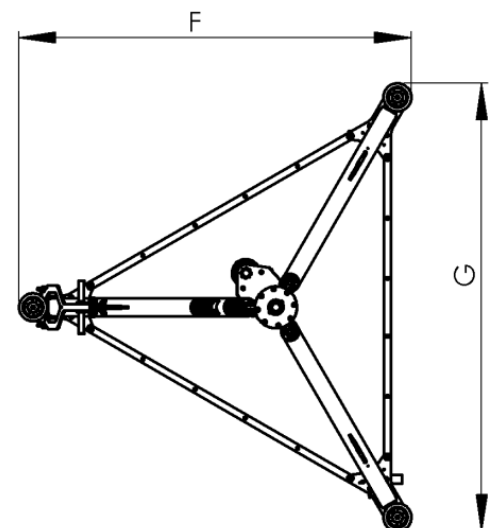
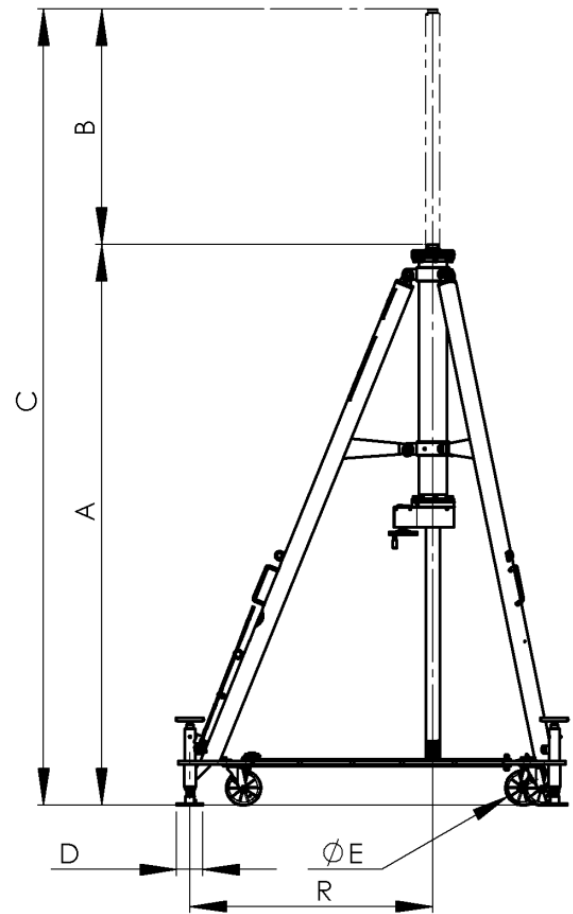

Capacity	A Min. height	B Jackscrew range	C Max. height	D	E	F	G	R
[t]	[mm]	[mm]	[mm]	[mm]	[mm]	[mm]	[mm]	[mm]
2	3215	1350	4565	150	200	2243	2567	1390
[tn sh.]	[inch]	[inch]	[inch]	[inch]	[inch]	[inch]	[inch]	[inch]
2.2	126.6	53.1	179.7	5.9	7.9	88.3	101.0	54.7

Packing information on request.

We reserve the right to update this datasheet at any time w/o prior notice!