

JMS AG

Rainer-Haungs-Straße 42
77933 Lahr/Germany

URL: <http://www.jms.aero/>
E-Mail: sales@jms.aero

**J-STAY08MX01**

Doc. No.: TDS_J-STAY08MX01_R02.docx

Datasheet J-STAY-series**Standard features:**

- Tripod steel frame
- Jackscrew, manually operated
- Interchangeable spherical jacking adapter, R3/4" concave
- Manually height adjustable foot pads
- Heavy-duty castors with locks
- 2K-PU SKYDROL-resistant paint
- Standard color RAL 1007 (daffodil yellow)

Options available:

- Tow-bar with \varnothing 76,2mm / 3" tow-eye
- Customized color in accordance with RAL color coding scheme

Documentation:

- Operation & maintenance manual incl. illustrated spare parts list
- Proof load test certificate
- COC (Certificate of Conformity)
- CE Declaration of Conformity

Aircraft application:

BOEING 737-100 through -900, BBJ, MAX -7/-8/-9
NOSE (SAFETY STAY)

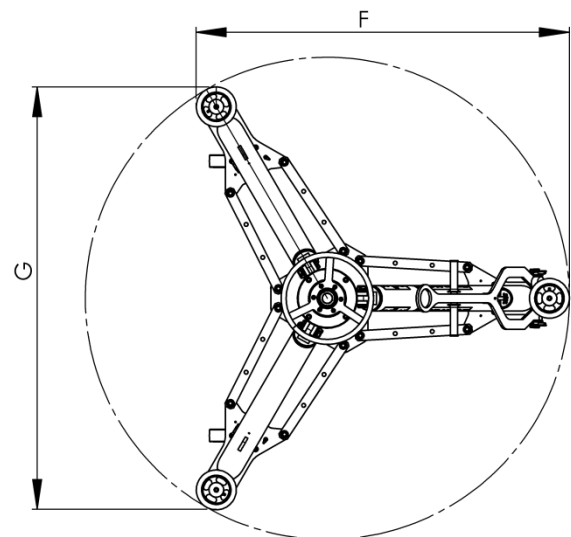
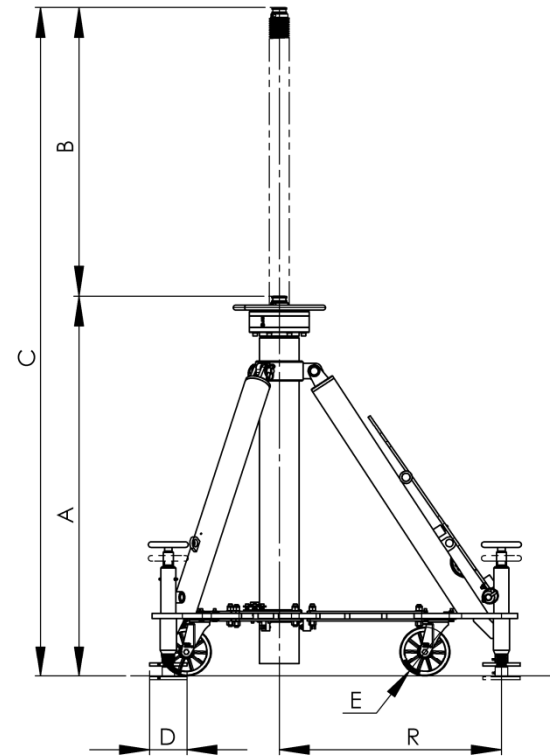

Picture may show options.

Capacity	A Min. height	B Jackscrew range	C Max. height	D	E	F	G	R
[t] 8	[mm] 1530	[mm] 1160	[mm] 2690	[mm] 150	[mm] 200	[mm] 1485	[mm] 1692	[mm] 890
[tn sh.] 8.8	[inch] 60.2	[inch] 45.6	[inch] 105.9	[inch] 5.9	[inch] 7.9	[inch] 58.5	[inch] 66.6	[inch] 35.0

Packing information on request.

We reserve the right to update this datasheet at any time w/o prior notice!