

J-TOW12

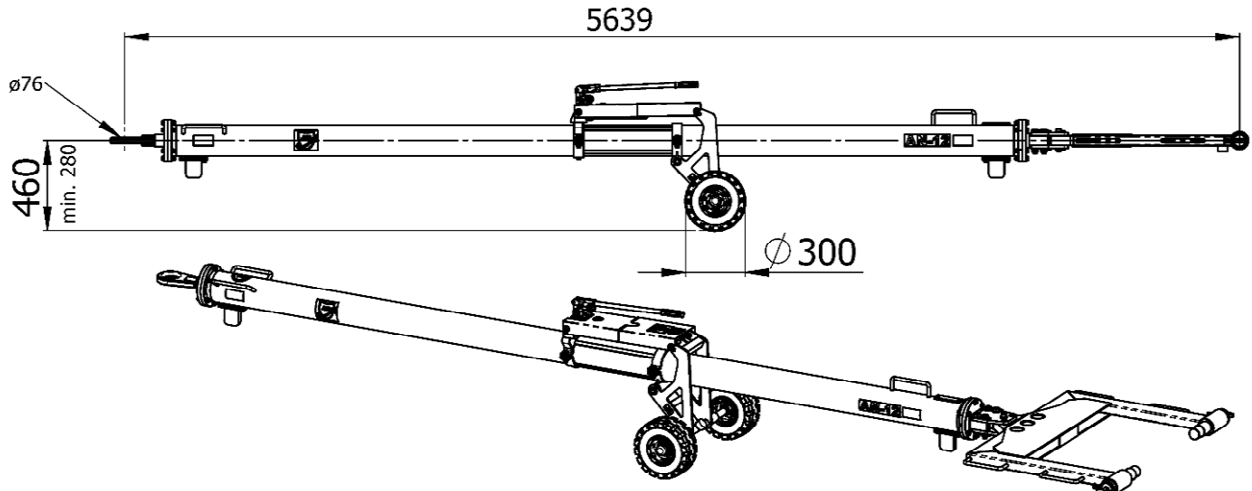

Standard features:

- 1xPush/Pull and 1xTorque shear pin mounted (add. as spare parts incl.: 2xPush/Pull and 2xTorque shear pins)
- 1xRetaining pin
- Air-inflated tires
- Hydraulically height adjustable undercarriage
- Steel tube
- Skydrol resistant paint
- Standard colors: yellow RAL 1007 (tube), black RAL 9004 (undercarriage)

Net weight:

- 275 kg / 606 lbs

Aircraft application:

- Antonov AN-12

Options (at extra charges):

- Puncture-proof (full rubber) tires
→ Option R3
- Floating axle
→ Option BV
- Revolving tow-eye with shock absorber
→ Option BA
- Revolving tow eye
→ Option BP
- Customized color for towbar tube i.a.w. RAL coding scheme
→ Option B-RAL

Documentation:

- Technical manual incl. illustrated spare parts list
- COC Certificate of Conformity
- CE Declaration of Conformity (if applicable)

Shear pins / Retaining pin:

- 00.41070.0013 "AL" Push/Pull and Torque
- 20-00850-0020-021 "H-FB" Retaining pin

Shipping dimensions incl. packaging:

Approx. Weight	Approx. shipping Dims l x w x h	Approx. Volume
[kg] 391	[mm] 5750 x 1050 x 965	[m ³] 5,8
[lbs] 862	[inch] 226 x 41 x 38	[ft ³] 205