

## J-TOW140

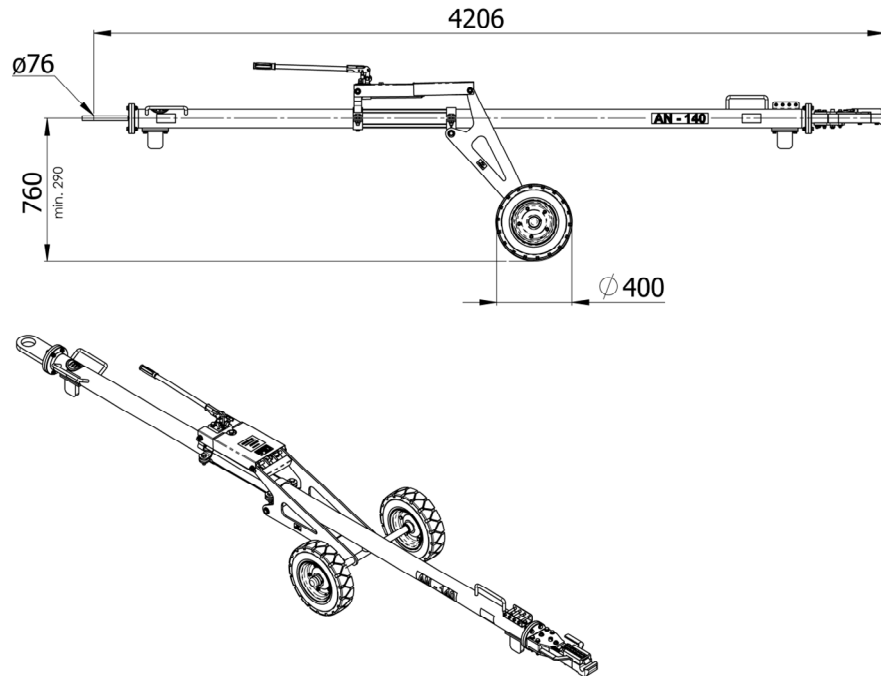

### Standard features:

- Push/Pull and torque shear pin
- 4 spare shear pins included
- Retaining pin
- Air-inflated tires
- Hydraulically height adjustable undercarriage
- Steel tube
- Skydrol resistant paint
- Standard colors:  
     yellow RAL 1007 (tube),  
     black RAL 9004 (undercarriage)

### Net weight:

- 137 kg / 302 lbs

### Aircraft application:

- Antonov AN-140

### Options (at extra charges):

- Puncture-proof (full rubber) tires  
     ➔ Option R4
- Revolving toweye  
     ➔ Option CP
- Revolving toweye with shock absorber  
     ➔ Option CA
- Customized color for towbar tube i.a.w.  
     RAL coding scheme  
     ➔ Option C-RAL

### Documentation:

- Technical manual incl. illustrated spare parts list
- COC Certificate of Conformity
- CE Declaration of Conformity (if applicable)

### Shear pins / Retaining pin:

- 00.36780.0012 "B" Push/Pull
- 00.37210.0013 "AC" Torque
- 20-00830-0020-021 "AC-FB" Retaining pin

### Shipping information incl. packing:

Approx. Weight	Approx. shipping Dims l x w x h	Approx. Volume
[kg] <b>253</b>	[mm] <b>4320 x 1050 x 965</b>	[m <sup>3</sup> ] <b>4,4</b>
[lbs] <b>558</b>	[inch] <b>170 x 41 x 38</b>	[ft <sup>3</sup> ] <b>155</b>