

## J-TOW146

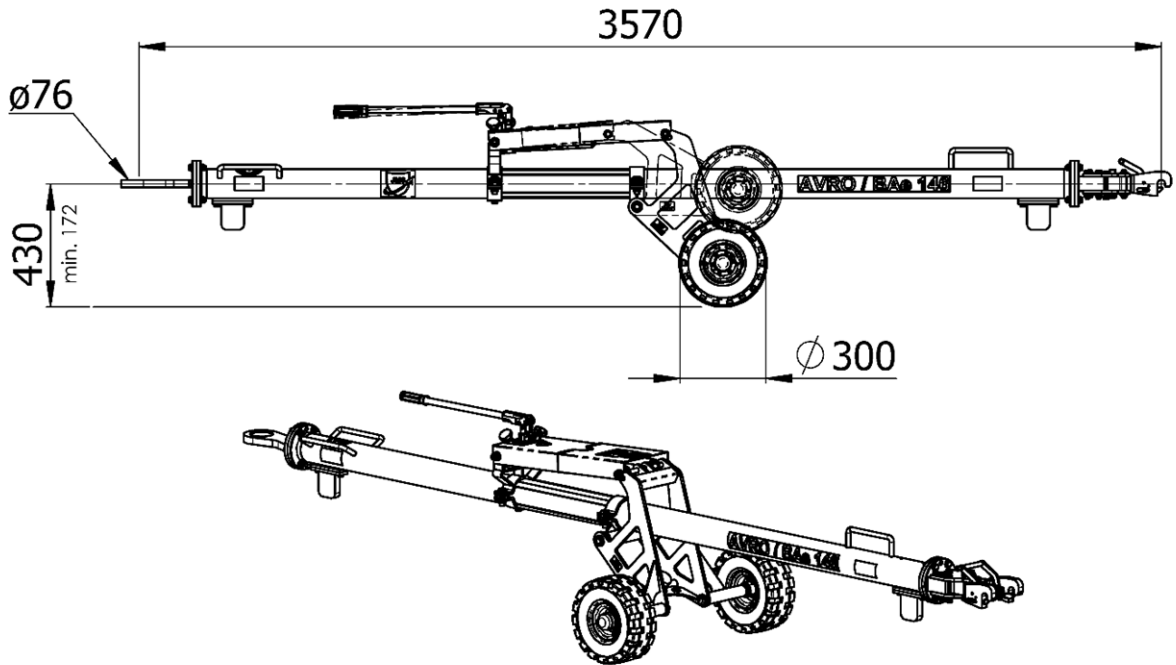

### Standard features:

- 1xPush/Pull and 1xTorque shear pin mounted, replaceable without using tools (add. as spare parts incl.: 1xPush/Pull and 1xTorque shear pin)
- 1xRetaining pin, replaceable without using tools
- Air-inflated tires
- Hydraulically height adjustable undercarriage
- Steel tube
- Skydrol resistant paint
- Standard colors: yellow RAL 1007 (tube), black RAL 9004 (undercarriage)

### Net weight:

- 120 kg / 265 lbs

### Aircraft application:

- Avro RJ
- Bae 146

### Options (at extra charges):

- Puncture-proof (full rubber) tires  
→ Option R3
- Revolving toweye  
→ Option CP
- Revolving toweye with shock absorber  
→ Option CA
- Customized color for towbar tube i.a.w. RAL coding scheme  
→ Option C-RAL

### Documentation:

- Technical manual incl. illustrated spare parts list
- COC Certificate of Conformity
- CE Declaration of Conformity (if applicable)

### Shear pins / Retaining pin:

- 00.37200.0012 "H" Push/Pull
- 00.36780.0009 "C" Torque
- 20-00020-0020-021 "D1-FB" Retaining pin

### Shipping information incl. packing:

Approx. Weight	Approx. shipping Dims l x w x h	Approx. Volume
[kg]	[mm]	[m <sup>3</sup> ]
<b>236</b>	<b>3950 x 1050 x 965</b>	<b>4,0</b>
[lbs]	[inch]	[ft <sup>3</sup> ]
<b>520</b>	<b>156 x 41 x 38</b>	<b>141</b>