

J-TOW170

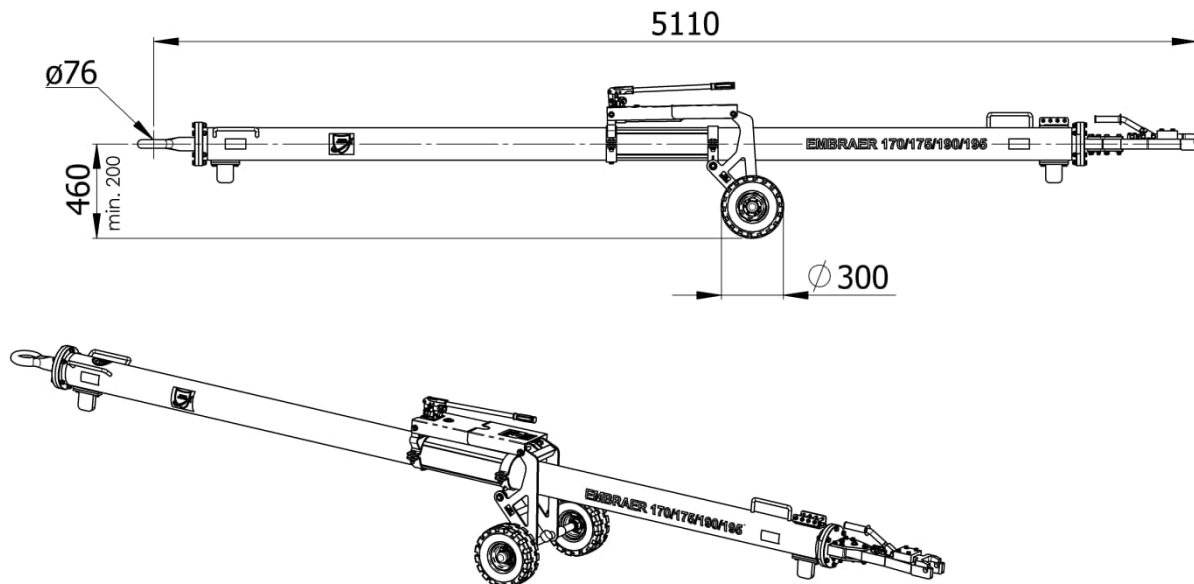

Standard features:

- 1xPush/Pull and 1xTorque shear pin mounted (add. as spare parts incl.: 2xPush/Pull and 2xTorque shear pins)
- 1xRetaining pin
- Air-inflated tires
- Hydraulically height adjustable (split axle) undercarriage
- Steel tube
- Skydrol resistant paint
- Standard colors: yellow RAL 1007 (tube), black RAL 9004 (undercarriage)

Net weight:

- 221 kg / 487 lbs

Aircraft application:)¹

- Embraer 170 / 175
- Embraer 190 SU/STD/LR/LU/AR/ECJ*
- Embraer 195 SU/LU/STD/LR/AR*
- Lineage 1000

*(Note: does not fit E2 models)

Options (at extra charges):

- Puncture-proof (full rubber) tires
 → Option R3
- Revolving tow-eye with shock absorber
 → Option BA
- Revolving tow eye
 → Option BP
- Customized color for towbar tube i.a.w. RAL coding scheme
 → Option B-RAL

Documentation:

- Technical manual incl. illustrated spare parts list
- COC Certificate of Conformity
- CE Declaration of Conformity (if applicable)

Shear pins / Retaining pin:

- 00.36910.0012 "D" Push/Pull
- 00.36910.0013 "E" Torque
- 20-00020-0020-21 "D1-FB" Retaining pin

Shipping dimensions incl. packaging:

Approx. Weight	Approx. shipping Dims l x w x h	Approx. Volume
[kg]	[mm]	[m ³]
337	5225 x 1050 x 965	5,3
[lbs]	[inch]	[ft ³]
743	206 x 41 x 38	187

)¹ Tow-bar currently not listed with aircraft OEM