

## J-TOW18

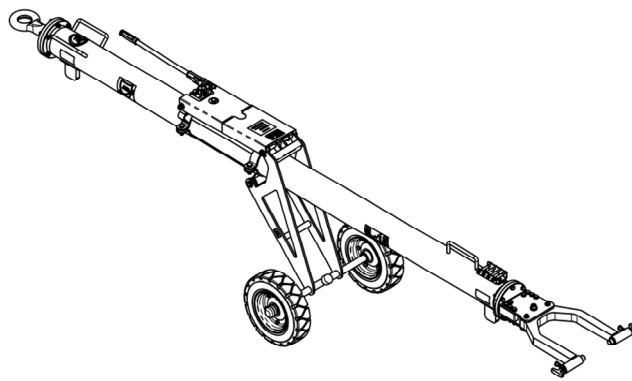
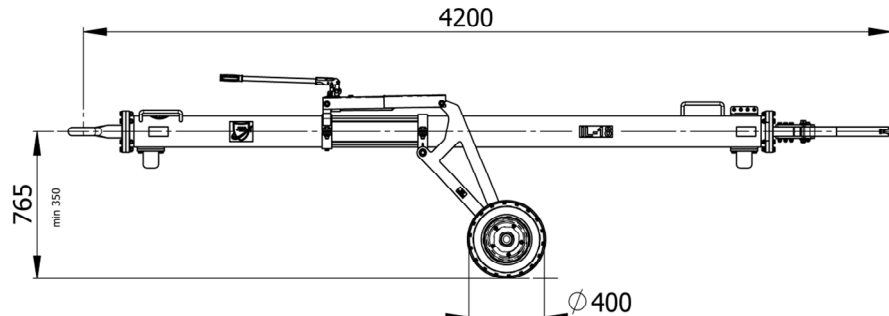

### Standard features:

- Air-inflated tires
- Hydraulically height adjustable undercarriage
- Steel tube
- Skydrol resistant paint
- Standard colors: yellow RAL 1007 (tube), black RAL 9004 (undercarriage)

### Net weight:

- 200 kg / 441 lbs

### Aircraft application:

- IL-18
- IL-38

### Options (at extra charges):

- Puncture-proof (full rubber) tires  
→ Option R4
- Revolving tow head  $\pm 10^\circ$   
→ Option BD
- Revolving tow-eye with shock absorber  
→ Option BA
- Revolving tow eye  
→ Option BP
- Customized color for towbar tube i.a.w. RAL coding scheme  
→ Option B-RAL

### Documentation:

- Technical manual incl. illustrated spare parts list
- COC Certificate of Conformity
- CE Declaration of Conformity (if applicable)

### Shipping dimensions incl. packaging:

Approx. Weight	Approx. shipping Dims l x w x h	Approx. Volume
[kg] <b>316</b>	[mm] <b>4300 x 1050 x 965</b>	[m <sup>3</sup> ] <b>4,4</b>
[lbs] <b>697</b>	[inch] <b>169 x 41 x 38</b>	[ft <sup>3</sup> ] <b>155</b>