

J-TOW204

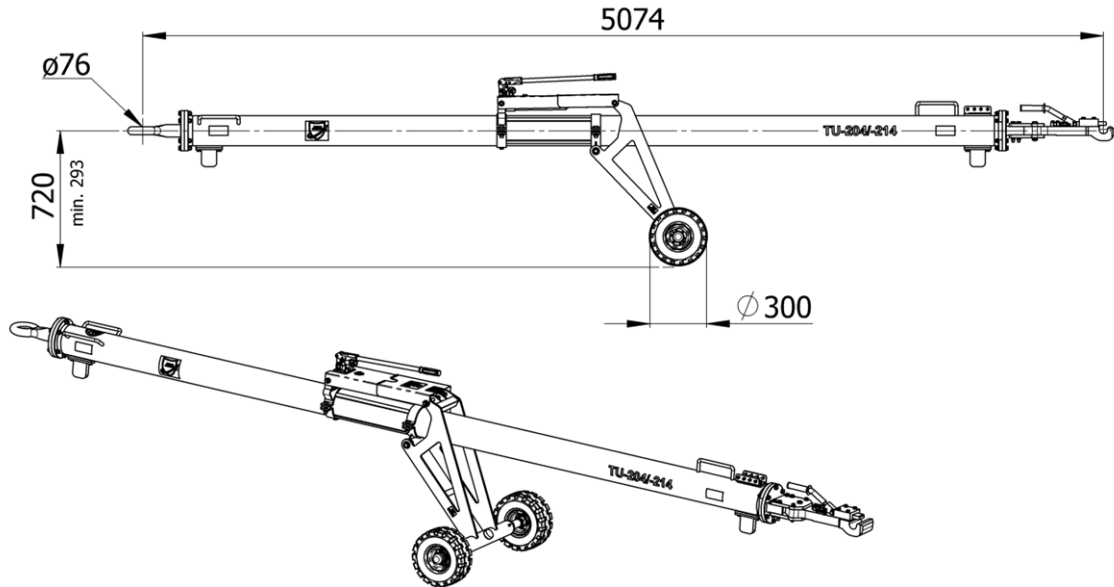

Standard features:

- 2xShearpins for Push/Pull / torque mounted (add. as spare parts incl.: 4xShearpins)
- 1xRetaining pin
- Air-inflated tires
- Hydraulically height adjustable undercarriage
- Steel tube
- Skydrol resistant paint
- Standard colors: yellow RAL 1007 (tube), black RAL 9004 (undercarriage)

Net weight:

- 220 kg / 485 lbs

Aircraft application:

- TU-204/-214

Options (at extra charges):

- Puncture-proof (full rubber) tires
→ Option R3
- Revolving tow head $\pm 10^\circ$
→ Option BD
- Revolving tow-eye with shock absorber
→ Option BA
- Revolving tow eye
→ Option BP
- Customized color for towbar tube i.a.w. RAL coding scheme
→ Option B-RAL

Documentation:

- Technical manual incl. illustrated spare parts list
- COC Certificate of Conformity
- CE Declaration of Conformity (if applicable)

Shear pins / Retaining pin:

- 00.40100.0016 "P1 Push/Pull and Torque"
- 00.40100.0018 "P1-FB" Retaining pin

Shipping dimensions incl. packaging:

Approx. Weight	Approx. shipping Dims l x w x h	Approx. Volume
[kg]	[mm]	[m ³]
336	5250 x 1050 x 965	5,3
[lbs]	[inch]	[ft ³]
741	207 x 41 x 38	187