

J-TOW767

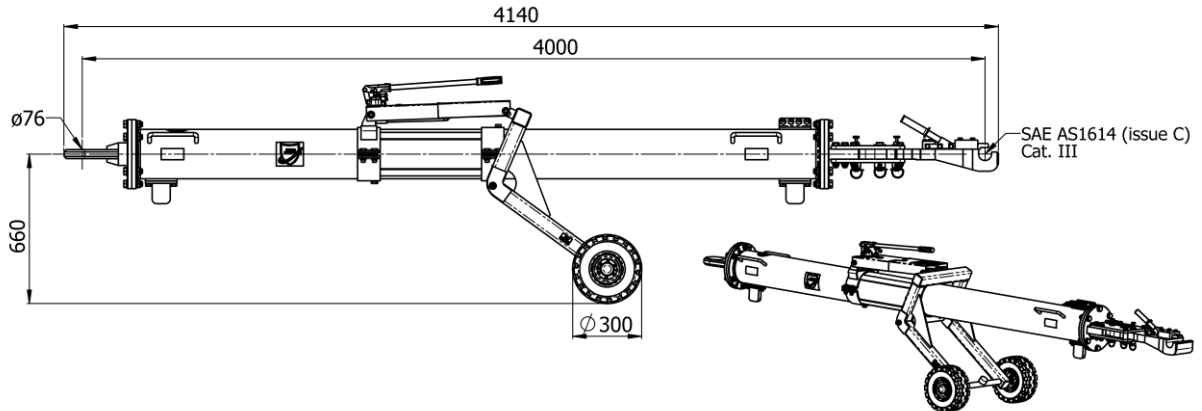

Standard features:

- 2xShearpins for Push/Pull / torque mounted, replaceable without using tools (add. as spare parts incl.: 4xShearpins)
- 1xRetaining pin
- FOD-Protection device:
No shear pin debris will be lost in case of shear pin fracture!
- Automatic locking mechanism
- Air-inflated tires
- Hydraulically height adjustable undercarriage
- Steel tube
- Skydrol resistant paint
- Standard colors: yellow RAL 1007 (tube), black RAL 9004 (undercarriage)

Net weight:

- 310 kg / 683 lbs

Aircraft application:

- B767

Options (at extra charges):

- Puncture-proof (full rubber) tires
→ Option R3
- Floating axle
→ Option AV
- Revolving tow head $\pm 10^\circ$
→ Option AD
- Revolving tow eye
→ Option AP
- Revolving tow eye with shock absorber
→ Option AA
- Customized color for towbar tube i.a.w. RAL coding scheme
→ Option A-RAL
- Mechanical shear break indicator
→ Option MSI

Documentation:

- Technical manual incl. illustrated spare parts list
- COC Certificate of Conformity
- CE Declaration of Conformity (if applicable)

Shear pins / Retaining pin:

- 20-01490-0020-122 "BQ" Push/Pull
- 20-01490-0020-125 "BS" Torque
- 20-01490-0020-021 "L1-FB" Retaining pin

Shipping information incl. packing (dismantled):

Approx. Weight	Approx. shipping Dims l x w x h	Approx. Volume
[kg]	[mm]	[m ³]
426	4500 x 1050 x 965	4,6
[lbs]	[inch]	[ft ³]
939	177 x 41 x 38	162