

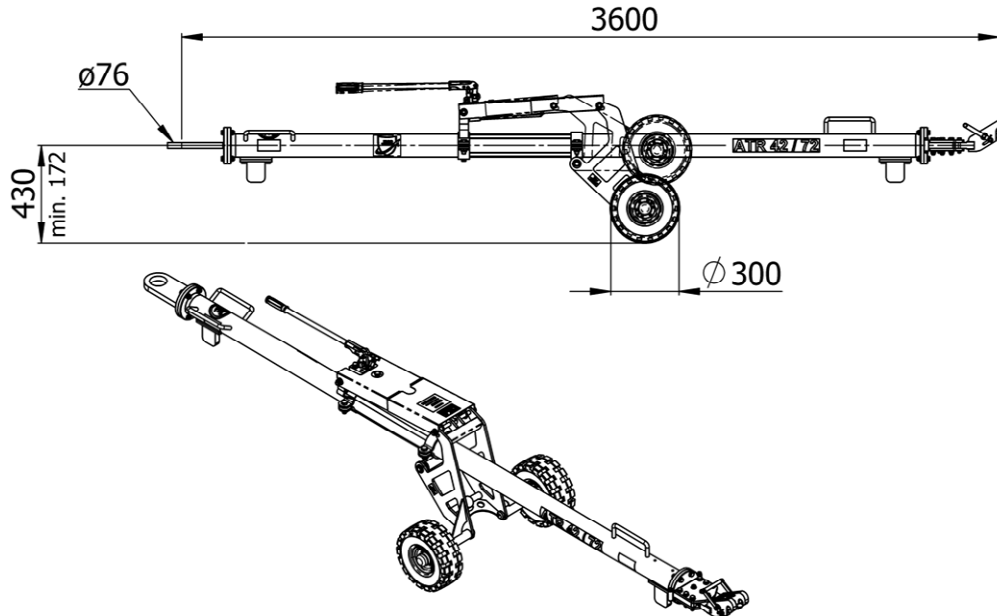

## J-TOWatr



### Standard features:

- Push/Pull and torque shear pin
- 2 spare shear pins included
- Retaining pin
- Air-inflated tires
- Hydraulically height adjustable undercarriage
- Steel tube
- Skydrol resistant paint
- Standard colors: yellow RAL 1007 (tube), black RAL 9004 (undercarriage)

### Net weight:

- 118 kg / 260 lbs

### Aircraft application:

- ATR42
- ATR72

### Options (at extra charges):

- Puncture-proof (full rubber) tires  
→ Option R3
- Revolving tow eye  
→ Option CP
- Revolving tow eye with shock absorber  
→ Option CA
- Customized color for towbar tube i.a.w. RAL coding scheme  
→ Option C-RAL

### Documentation:

- Technical manual incl. illustrated spare parts list
- COC Certificate of Conformity
- CE Declaration of Conformity (if applicable)

### Shear pins / Retaining pin:

- 00.36360.0016 "G" Push/Pull
- 00.36360.0012 "F" Torque
- 20-00480-0020-021 "G-FB" Retaining pin

### Shipping information incl. packing:

Approx. Weight	Approx. shipping Dims l x w x h	Approx. Volume
[kg] <b>216</b>	[mm] <b>3700 x 1050 x 840</b>	[m <sup>3</sup> ] <b>3,3</b>
[lbs] <b>476</b>	[inch] <b>146 x 41 x 33</b>	[ft <sup>3</sup> ] <b>116</b>