

## J-TOWc100

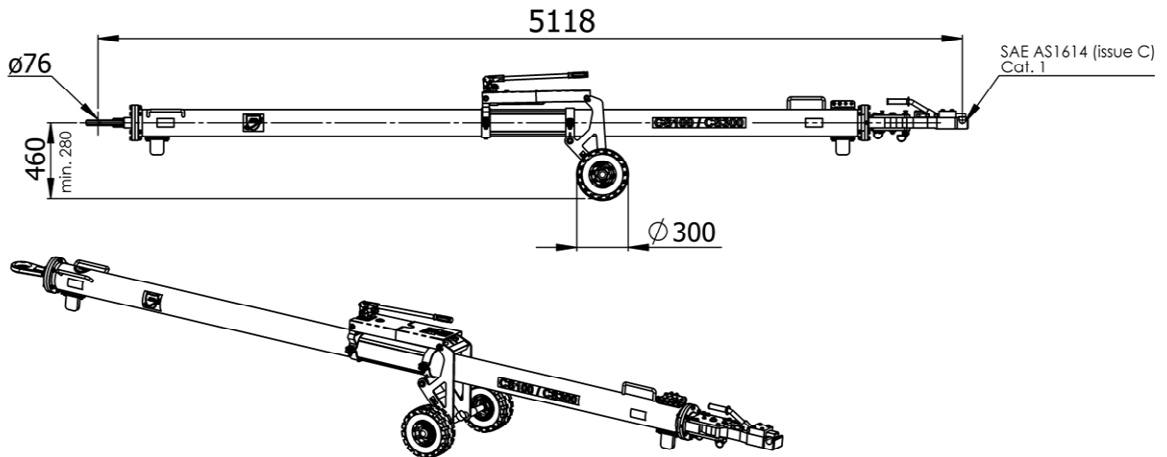

### Standard features:

- 1xPush/Pull and 1xTorque shear pin mounted, replaceable without using tools (add. as spare parts incl.: 2xPush/Pull and 2xTorque shear pins)
- 1xRetaining pin, replaceable without using tools
- FOD-Protection device:  
No shear pin debris will be lost in case of shear pin fracture!
- Automatic locking mechanism
- Air-inflated tires
- Hydraulically height adjustable undercarriage
- Revolving tow head  $\pm 10^\circ$   
(required due to NLG at an angle)
- Steel tube
- Skydrol resistant paint
- Standard colors: yellow RAL 1007  
black RAL 9004 (undercarriage)

### Net weight:

- 232 kg / 511 lbs

### Aircraft application:

- A220 -100/-300  
(formerly Bombardier - CS100 / CS300)

### Options (at extra charges):

- Puncture-proof (full rubber) tires  
→ Option R3
- Floating axle  
→ Option BV
- Revolving tow eye  
→ Option BP
- Revolving tow eye with shock absorber  
→ Option BA
- Customized color for towbar tube i.a.w. RAL coding scheme  
→ Option B-RAL

### Documentation:

- Technical manual incl. illustrated spare parts list
- COC Certificate of Conformity
- CE Declaration of Conformity (if applicable)

### Shear pins / Retaining pin:

- 20-01080-0020-022 "BC" Push/Pull
- 20-01080-0020-025 "BD" Torque
- 20-01080-0020-021 "BC-FB" Retaining pin

### Shipping information incl. packing:

Approx. Weight	Approx. shipping Dims l x w x h	Approx. Volume
[kg]	[mm]	[m <sup>3</sup> ]
<b>348</b>	<b>5320 x 1050 x 965</b>	<b>5,4</b>
[lbs]	[inch]	[ft <sup>3</sup> ]
<b>767</b>	<b>209 x 41 x 38</b>	<b>191</b>